

Clip-in Wireless Shutter/Blind Switch

EWNWCBLI Series



This product is a connected accessory which requires you to buy and install the Excel Life™ Smart Starter Kit and Smart Shutter/ Blind Switches or Micromodules first.

This product only controls Excel Life™ Smart Shutter/Blind Switches or Micromodules.

Clip-in Wireless Shutter/Blind Switches

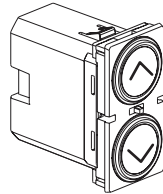

Frequency bands: 2.4 - 2.4835 GHz
Power level: <100 mW

Installing the Clip-in Shutter/Blind Wireless Switch

- The Clip-in Wireless Shutter/Blind Switch can only be installed in Excel life™ Smart Grid & Plates: EWN1GPL, EWN2GPL, EWN3GPL, EWN4GPL, EWN5GPL and EWN6GPL series.

To add the clip-in Shutter/ Blind Wireless Switch to your connected installation, you should follow the instructions:
- in the Legrand Home + Control application (Settings / Add a new product section)
- or consult ecat.legrand.com.au

Replacing the battery

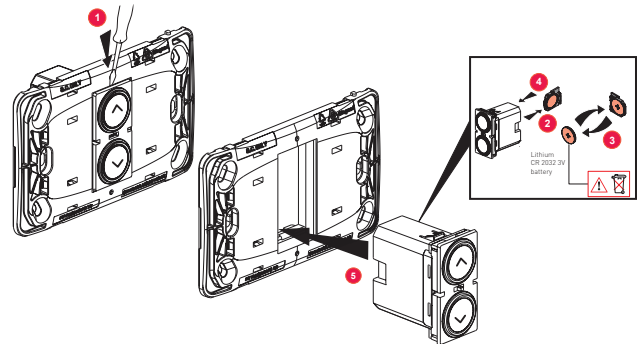

Clip-in Wireless Shutter/Blind Switch

EWNWCBLI Series



This product is a connected accessory which requires you to buy and install the Excel Life™ Smart Starter Kit and Smart Shutter/ Blind Switches or Micromodules first.

This product only controls Excel Life™ Smart Shutter/Blind Switches or Micromodules.

Clip-in Wireless Shutter/Blind Switches

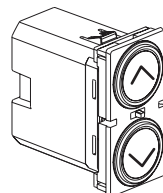

Frequency bands: 2.4 - 2.4835 GHz
Power level: <100 mW

Installing the Clip-in Shutter/Blind Wireless Switch

- The Clip-in Wireless Shutter/Blind Switch can only be installed in Excel life™ Smart Grid & Plates EWN1GPL, EWN2GPL, EWN3GPL, EWN4GPL, EWN5GPL and EWN6GPL series.

To add the clip-in Shutter/ Blind Wireless Switch to your connected installation, you should follow the instructions:
- in the Legrand Home + Control application (Settings / Add a new product section)
- or consult ecat.legrand.com.au

Replacing the battery

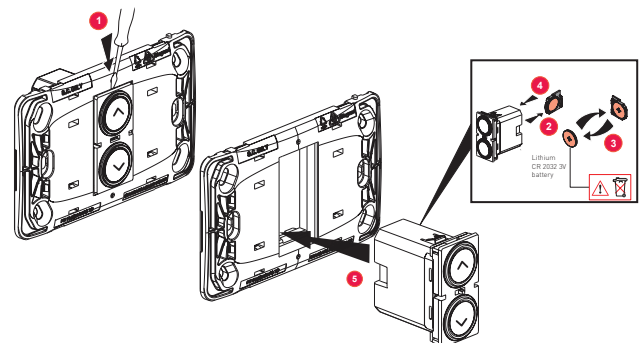

Clip-in Wireless Shutter/Blind Switch

EWNWCBLI Series



Product Notes

- For indoor use only.
- This product must be installed and used as per these instructions.
- This product is not suitable for installation in hazardous and/or corrosive areas.
- This product should not be installed in areas exposed to constant vibration, temperature fluctuations, or areas of high humidity.
- This product contains no serviceable parts and no attempt should be made to repair this product. If the product is faulty it should be discarded.
- This product has been designed to operate in ambient temperatures 5°C to 25°C.
- The material in this product may vary in colour from batch to batch. Colour matching from one batch to another cannot be guaranteed.
- Extended exposure to UV rays (such as exposure to direct sunlight) may cause discolouration of this product.
- This product utilises intellectual property in the form of registered designs, trademarks, and/or patents. Such intellectual property remains the property of Legrand in all cases.
- Legrand reserves the right to modify the specification of this product at anytime.

Warranty

These goods come with guarantees that cannot be excluded under the Australian and New Zealand Consumer Laws. You are entitled to a replacement or a refund for a major failure and compensation for any other reasonably foreseeable loss or damage. You are also entitled to have the goods repaired or replaced if the goods fail to be of acceptable quality and the failure does not amount to a major failure.

Customer Service

For all Customer Service and Technical Support enquiries please call Monday to Friday during business hours.

Legrand Australia
1300 369 777
www.legrand.com.au
ABN: 31 000 102 661

Legrand New Zealand
0800 476 009
www.legrand.co.nz

05/2023
LE14332AA

Clip-in Wireless Shutter/Blind Switch

EWNWCBLI Series



Product Notes

- For indoor use only.
- This product must be installed and used as per these instructions.
- This product is not suitable for installation in hazardous and/or corrosive areas.
- This product should not be installed in areas exposed to constant vibration, temperature fluctuations, or areas of high humidity.
- This product contains no serviceable parts and no attempt should be made to repair this product. If the product is faulty it should be discarded.
- This product has been designed to operate in ambient temperatures 5°C to 25°C.
- The material in this product may vary in colour from batch to batch. Colour matching from one batch to another cannot be guaranteed.
- Extended exposure to UV rays (such as exposure to direct sunlight) may cause discolouration of this product.
- This product utilises intellectual property in the form of registered designs, trademarks, and/or patents. Such intellectual property remains the property of Legrand in all cases.
- Legrand reserves the right to modify the specification of this product at anytime.

Warranty

These goods come with guarantees that cannot be excluded under the Australian and New Zealand Consumer Laws. You are entitled to a replacement or a refund for a major failure and compensation for any other reasonably foreseeable loss or damage. You are also entitled to have the goods repaired or replaced if the goods fail to be of acceptable quality and the failure does not amount to a major failure.

Customer Service

For all Customer Service and Technical Support enquiries please call Monday to Friday during business hours.

Legrand Australia
1300 369 777
www.legrand.com.au
ABN: 31 000 102 661

Legrand New Zealand
0800 476 009
www.legrand.co.nz

05/2023
LE14332AA